

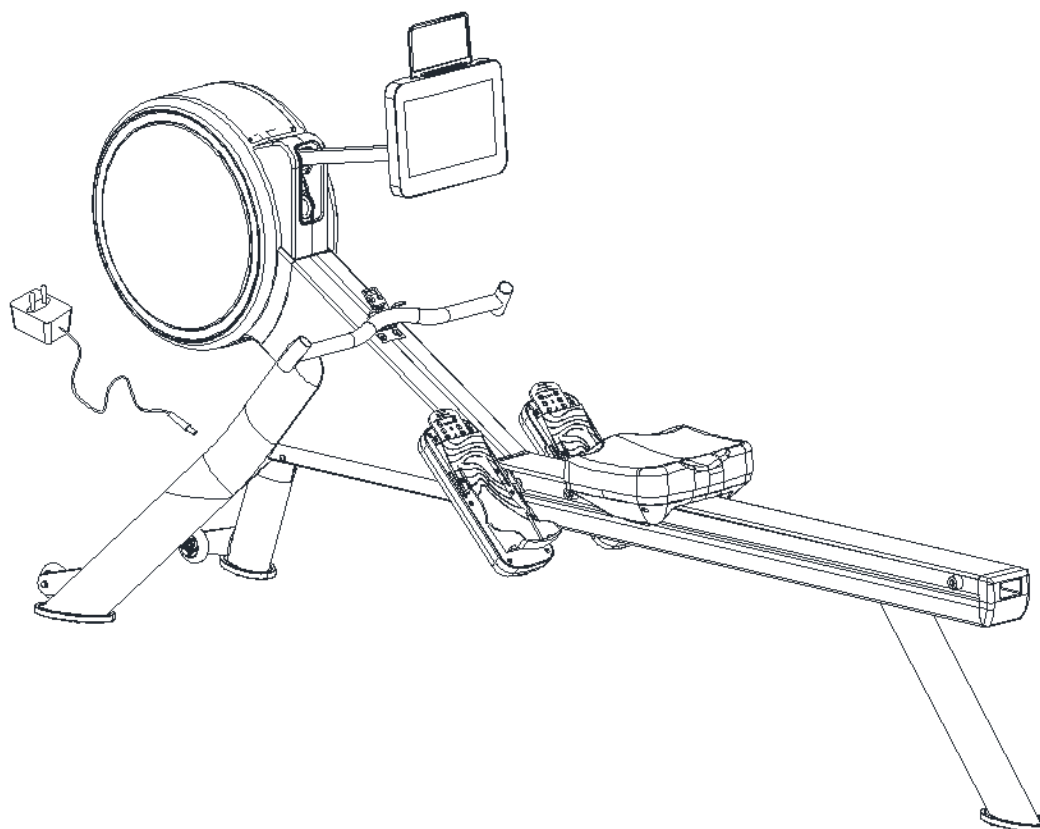

USER MANUAL – EN
IN 25782 Rowing Machine inSPORTline ZenRow



CONTENTS

SAFETY INSTRUCTIONS..... 3
DIAGRAM..... 4
PARTS LIST 7
ASSEMBLY 9
MAINTENANCE 12
TRANSPORT..... 13
CONSOLE 14
WARM UP 17
HOW TO EXERCISE..... 20
IMPORTANT NOTICE 20
ENVIRONMENT PROTECTION 21
TERMS AND CONDITIONS OF WARRANTY, WARRANTY CLAIMS..... 21

SevenSport s.r.o. reserves the right to make any changes and improvements to its product without prior notice. Visit our website www.insportline.eu where you will find the latest version of the manual.





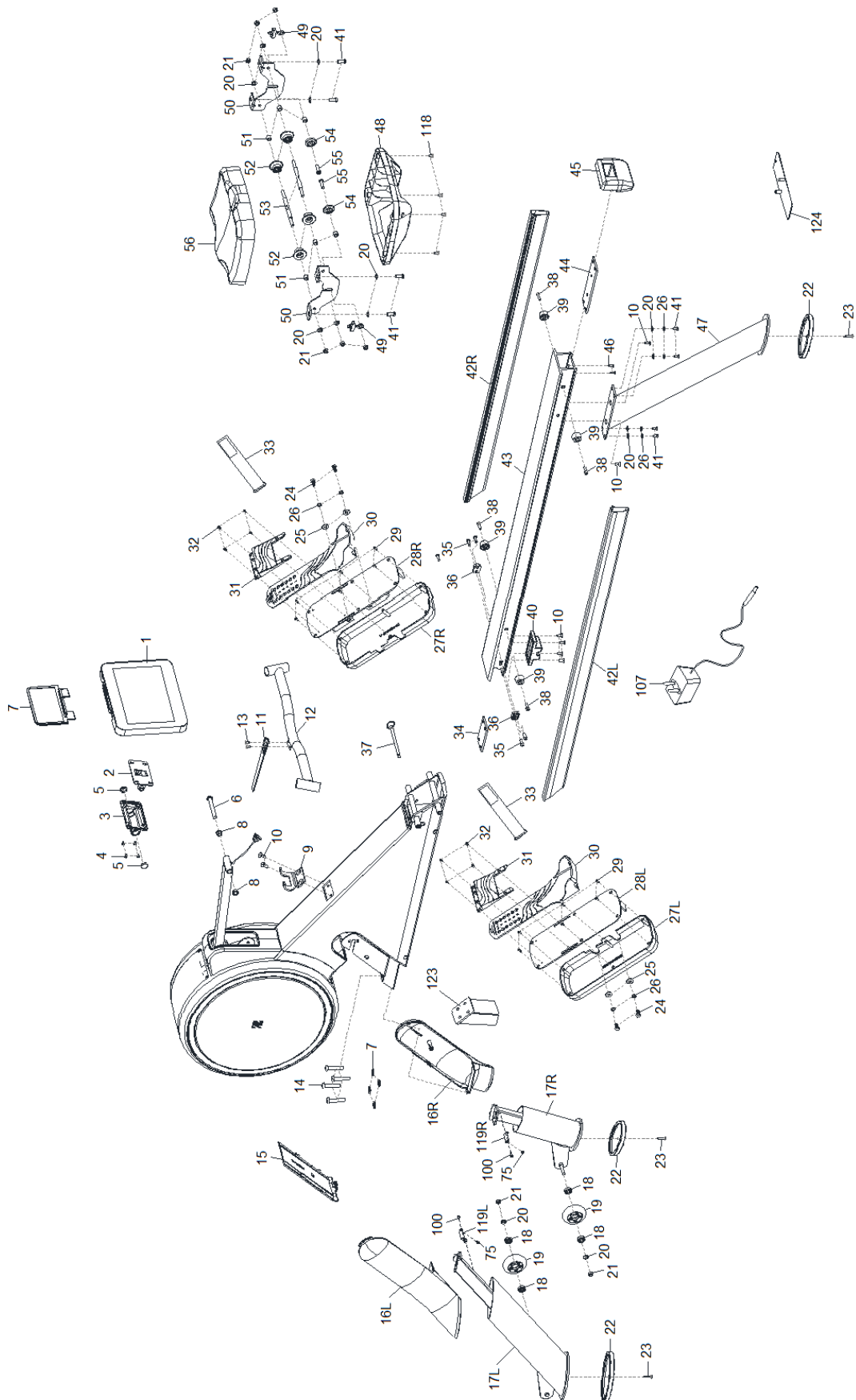

SAFETY INSTRUCTIONS

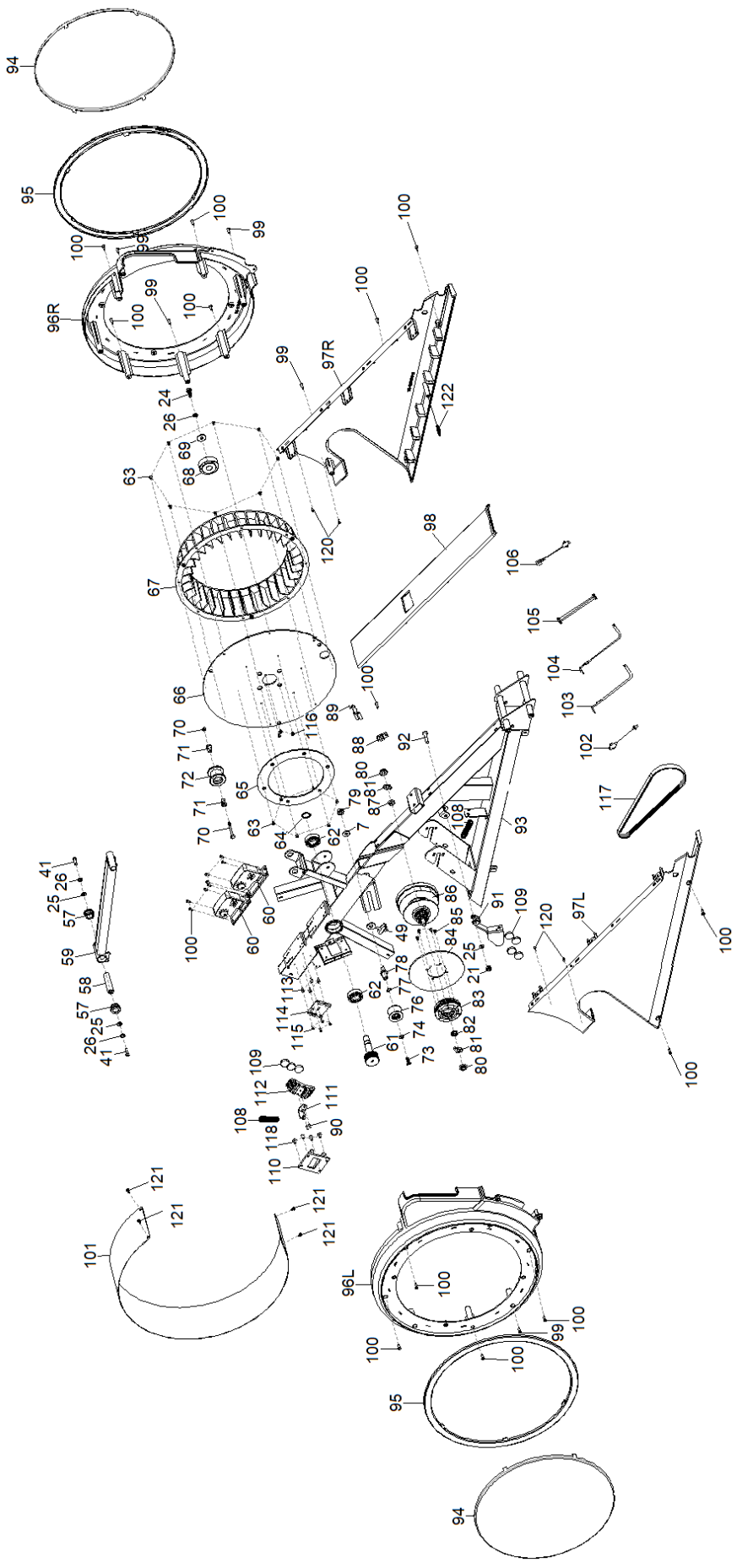
- Read this manual carefully before first using and retain it for future reference.
- Observe all warnings and precautions including assembly steps. Use it only for intended purpose.
- Assemble and use it only according to this manual to assure your safety. Inform all other users about safe usage.
- Keep it away from children and pets. Don't let children unattended near this device. Only an adult person may assemble and use it.
- Ask your physician for advice before starting any exercise program. It is especially necessary if you suffer from some health problems or if you take some medication that could affect your heart rate, blood pressure or cholesterol level.
- Observe body signals. If you feel some problems (pain, tightness in chest, irregular heartbeat, breathing shortness, dizziness or nausea), stop immediately. Improper exercising can result in serious health problems or in an injury.
- Put it only on a flat, dry and clean surface and keep a safety clearance of at least 0.6 m from other objects for higher safety. Use a protective cover to protect carpet or floor.
- Wear adequate sports clothes and sports shoes. Avoid too loose clothes.
- Don't use it outdoors.
- Check this device for damage or wearing before each using. Regularly check all bolts and nuts. They should be well tightened. Re-tighten, if necessary. Never use damaged or worn device to assure your safety.
- If some sharp edges occur, stop using.
- If you hear some unusual noises coming from this device, stop using.
- No adjustable part should protrude and obstruct user movements. Only one person may use it at time.
- It is not intended for therapeutic purpose.
- Pay attention while lifting or transporting it to avoid back injury. Use only proper lifting techniques or ask some other person for help.
- Don't do any improper modification of this product. If necessary, contact authorized service.
- **Weight limit:** 150 kg
- **Category:** HC according to EN 957 for home use
- **WARNING!** The heart rate frequency monitoring may not be completely accurate. Overexertion during training can lead to a serious injury or even death. If you start to feel faint, stop the exercise immediately.

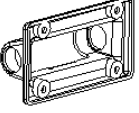
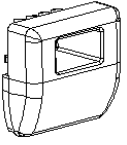
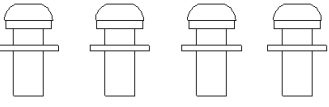
DIAGRAM

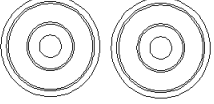
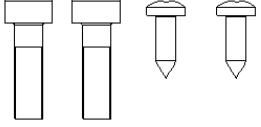
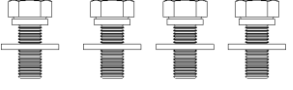
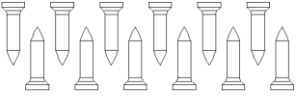

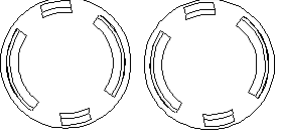

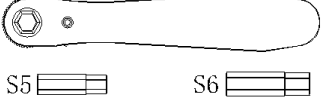
	#3 – 117x60x48; 1x
	#45 – 110x100x30,5; 1x
Krok 3	
	#41 – Bolt M8x20xS3; 4x #26 – Spring washer d8; 4x #20 – Washer Ø16x1,5; 4x
Krok 4	
	#37 – Pin Ø8x115x120; 1x
Krok 5	
	#39 – Ø27xØ23x16xØ6; 2x
	#38 – M6x20xS5; 2x #46 – ST4,2x13; 2x
Krok 6	
	#24 – Bolt M8x20xS13; 4x #25 – Washer D8xØ20x2; 4x #26 – Spring washer Ø8; 4x
	#29 – Bolt ST4x19; 12x
Krok 7	
	#6 – Bolt M5x80x20xS6; 1x
	#5 – End cap Ø22x6; 2x
	#B
	#A

PARTS LIST

No.	Name	Qty.	No.	Name	Qty.
1	Console	1	37	Pin	1
2	Console holder	1	38	Bolt M6x20	4
3	Console bottom cover	1	39	Stopper	4
4	Bolt M5x20	4	40	Bottom fixing of the stopper	1
5	Cover	2	41	Bolt M8x20	10
6	Bolt M10x80x20xS6	1	42L/R	Aluminum guiding rail cover L/R	1
7	Tablet holder	1	43	Aluminum guide rail	1
8	Sleeve Ø18	2	44	Plate	1
9	Handle holder	1	45	Guide rail rear cover	1
10	Bolt M8x20xS5	8	46	Screw ST4,2	2
11	Pulling belt	1	47	Rear stabilizer	1
12	Handle	1	48	Seat cover	1
13	Bolt M5x6	2	49	Chain assembly	3
14	Bolt M10x50x15xS6	4	50	Saddle frame	2
15	Back cover	1	51	Case Ø12.5x Ø802x11.3	6
16L/R	Stabilizer covers left / right	1pair	52	Wheels Ø40	4
17L/R	Stabilizers	1pair	53	Axis Ø10x150	2
18	Bearings 608	4	54	Wheels Ø34	2
19	Wheels	2	55	Bolt M8x32	2
20	Washers	14	56	Seat	1
21	Nut M8	9	57	Sleeve	2
22	Legs	3	58	Display rotation shaft	1
23	Self-tapping screw	3	59	Console frame	1
24	Bolt M8x20	5	60	Motor	2
25	Washer D8x Ø20	7	61	Motor fan shaft	1
26	Spring washer	11	62	Bearing 6203	2
27L/R	Pedal cover	1pair	63	Bolt M4x8	14
28L/R	Pedal holder	1pair	64	Retaining ring	1
29	Self-tapping screw	12	65	Aluminum plate D17	1
30L/R	Pedal	1pair	66	Fan axis fixing plate	1
31	Pedal fastening	2	67	Rotating fan wheel	1
32	Bolt M4x6	8	68	Fan wheel sleeve	1
33	Pedal strap	2	69	Washer D6	1
34	Plate	1	70	Bolt M6x10	1
35	Bolt M6x20xS5	4	71	Belt housing	2
36	Middle frame	2	72	Belt pulley	1

73	Bolt M6x55	1	100	Self-tapping screw	24
74	Pad D6	1	101	Arc steel net	1
75	Self-tapping screw	4	102	Wire	1
76	Freewheel	1	103	Resistance wire 1	1
77	Corrugated pad D12	1	104	Resistance wire 2	1
78	Freewheel shaft	1	105	Extension wire 2	1
79	Nylon nut M10	1	106	Power extension cable	1
80	Nut M10	2	107	Adapter	1
81	Fixing ring	2	108	Spring	2
82	Nut M10	1	109	Round magnet	7
83	Small belt wheel	1	110	Magnetic frame	1
84	Aluminum ring	1	111	Suspension cable for the saddle	1
85	Screw ST4.2	4	112	Magnetic plate	1
86	Pulley	1	113	Connecting pin	4
87	Hexagonal nut M10	1	117	Belt	1
88	Dual head sensor	1	114	Bottom PCB board	1
89	Sensor pin	2	115	Phillips head screw M3	4
90	Phillips head screw	2	116	Hexagon bolt M5	3
91	Magnetic plate frame	1	118	Phillips head screw M5	8
92	Bolt M8	1	119L/R	Fixation plate	1
93	Main frame	1	120	Self-tapping screw	4
94	Steel net cover	2	121	Cross self-tapping screw	4
95	Decorative ring	2	122	Connecting pin	1
96L/R	Chain cover	2	123	Column	1
97L/R	Side cover	2	124	Auxiliary mounting plate	1
98	A top cover	1	A	Ratchet	1
99	Self-tapping screw	5	B	Wrench	1

ASSEMBLY

Assembly may only be carried out by adults. Ask another person for help.

Step 1

Place the two polystyrenes on top of each other and place the main frame (93) on top of them.

Unscrew the 2x bolts (14) from the main frame (93). (Fig. 1)

Attach the left stabilizer (17L) to the main frame (93) with 2x bolts (14). (Fig. 2)

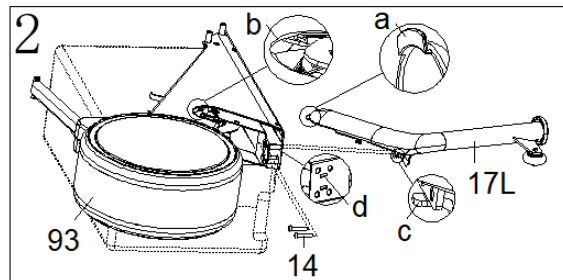
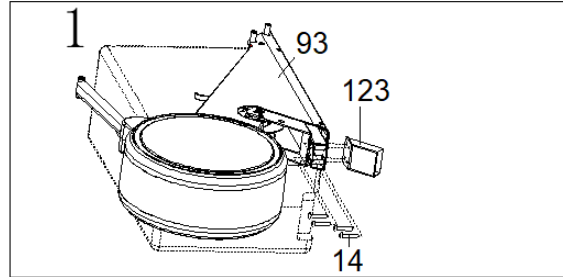
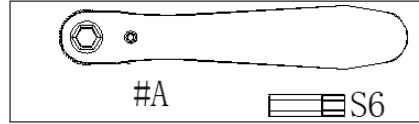
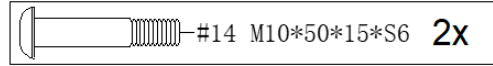

Step 2

Turn the main frame to the other side.

Attach the right stabilizer (17R) to the main frame (93) with 2x bolts (14). (Fig. 1)

Connect cables (102) and (106). (Fig. 2)

Attach the cover (15) to the main frame (93). (Fig. 2)

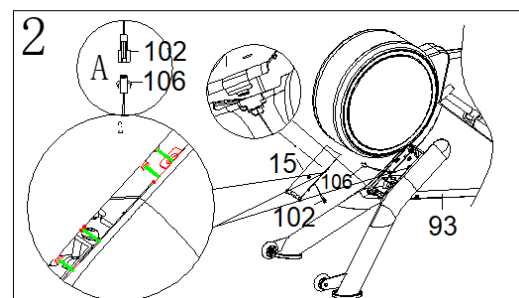
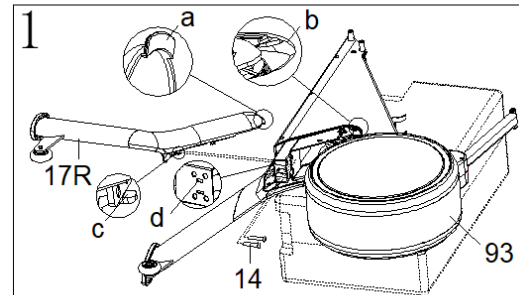
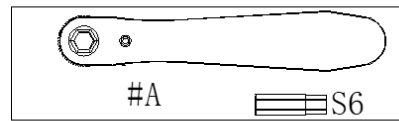
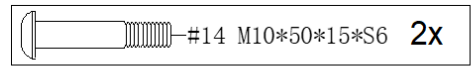

Step 3

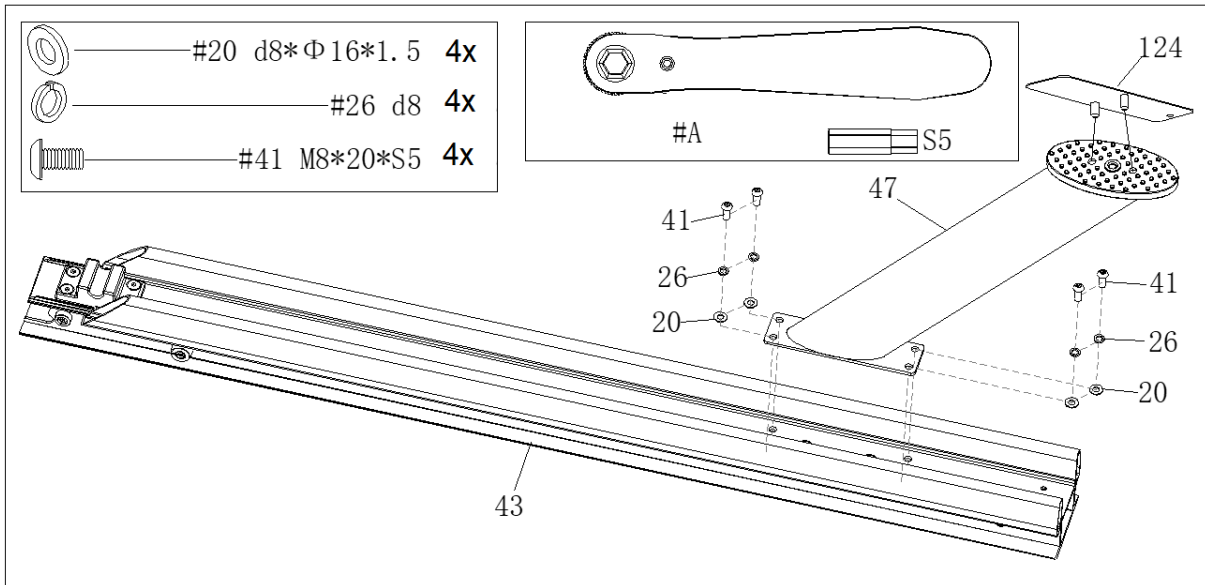

Attach the rear stabilizer (47) to the guiding frame (43) using 4x bolts (41), 2x spring washers (26) and 4x washers (20).

Attach the auxiliary mounting plate (124) to the rear stabilizer (47).

Step 4

Align the main frame (93) with the guiding frame (43). Make sure both parts are perfectly aligned before connecting.

Insert the guiding frame (43) into the main frame (93) and secure part (a, main frame 93) to part (b, guiding frame 43). (Fig. 1 and 2)

Slowly connect the two parts of the frame, the frames must be connected at points (d, main frame 93) and (c, guiding frame 43) (Fig. 3 and 4)

Secure with pin (37). (Fig. 5)

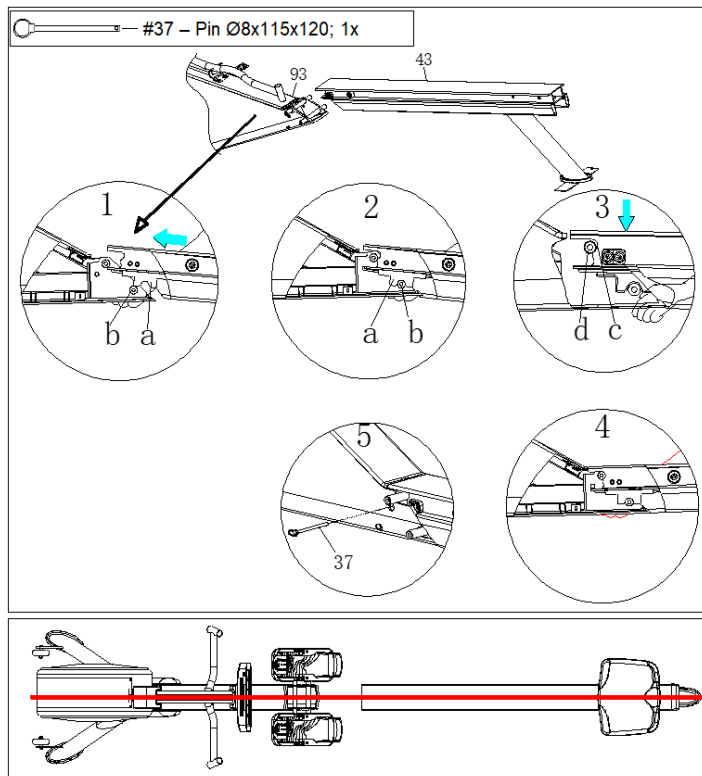

Step 5

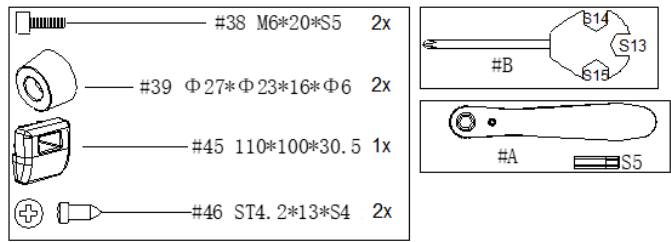

Slide the saddle (56) into the guiding frame (43), making sure the saddle is facing the right direction.

Attach 2x stoppers (39) to the guiding frame using 2x bolts (38).

Attach the back cover (45) to the guiding frame (43) with 2x bolts (46).

You can attach the pin (37) to the guiding frame (37) to prevent the saddle from moving when dismounting.

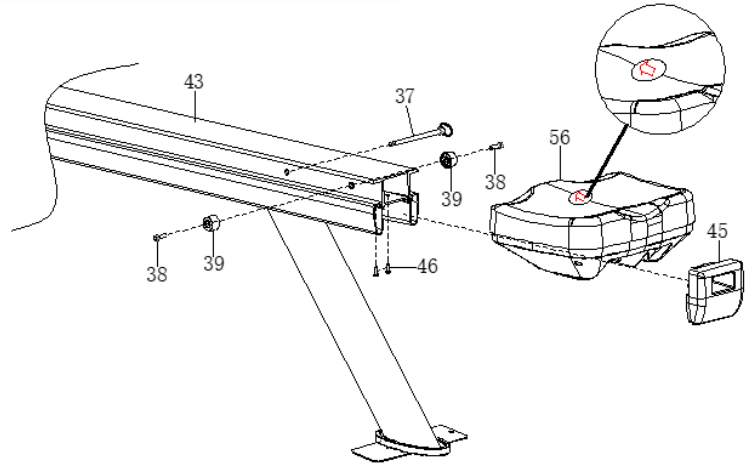

Step 6

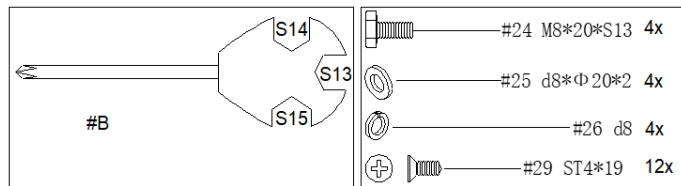

Attach the pedals (30 L/R) to the main frame (93) using 4x bolts (24), 4x spring washers (26) and 4x washers (25).

Attach the pedal covers (27 L/R) to the pedal frames (31 L/R) with bolts (29).

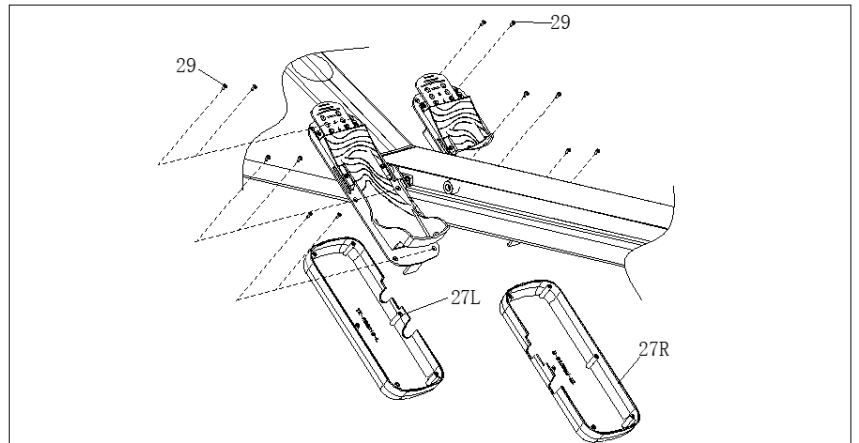
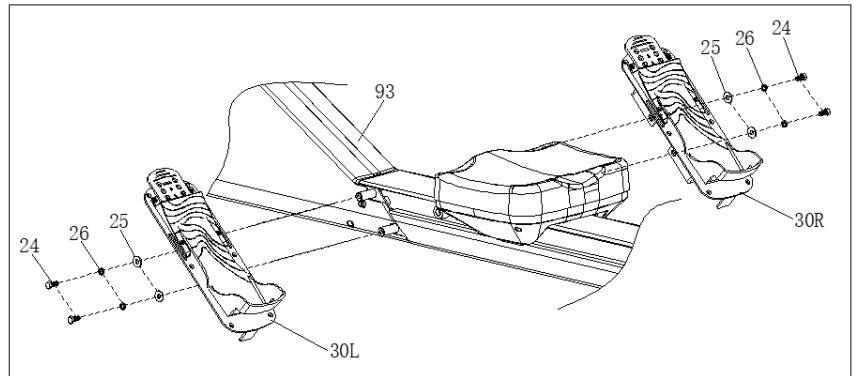

Step 7

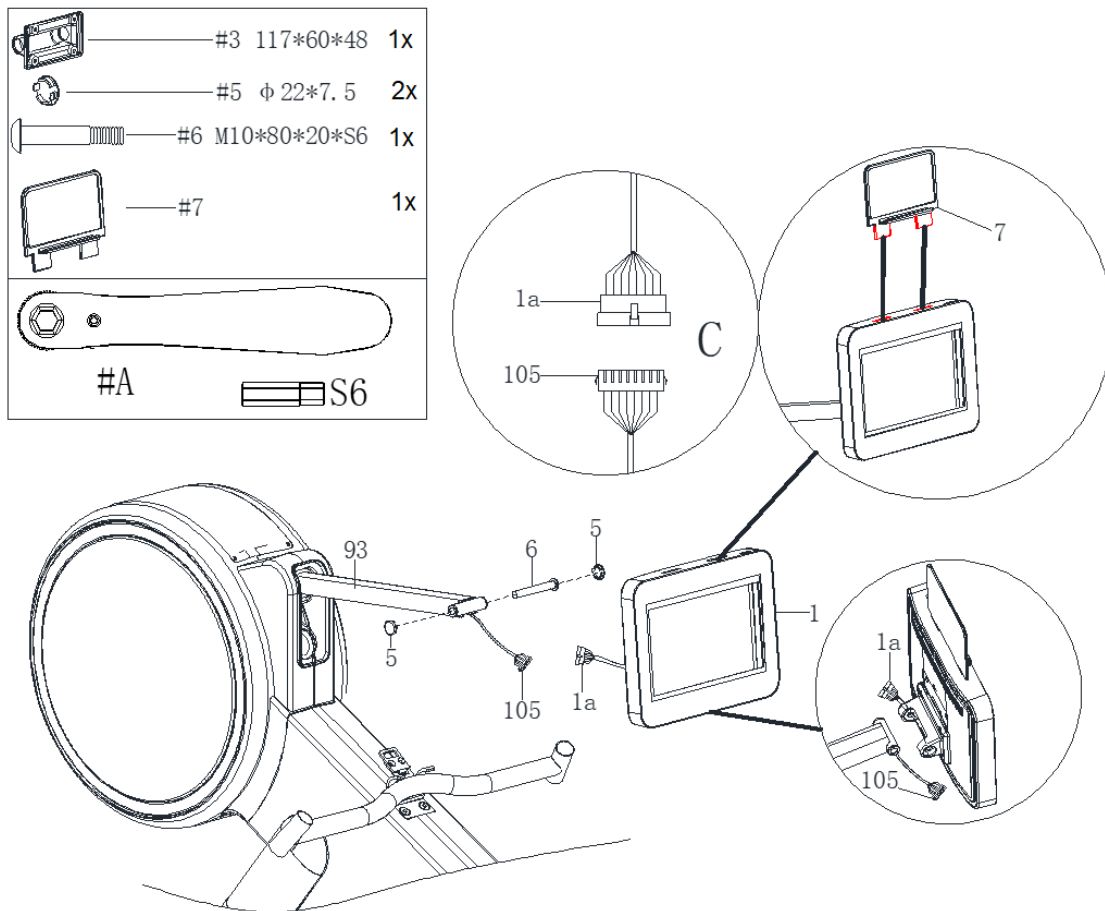

Attach the console (1) to the main frame (93) with the bolt (6) and then attach the 2x end caps (5). Connect the cable (1a) and (105), then insert the cable into the main frame (93). Attach the tablet holder (7) to the console (1).

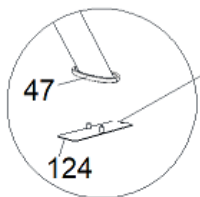

Remove the auxiliary mounting plate (124) before using the machine.

MAINTENANCE

- After use, wipe the machine from sweat and dirt with a soft cloth.
- Do not use aggressive cleaning agents for cleaning (solvents, agents based on alcohol, benzene, etc.)
- Regularly check the condition of the machine and the connection.
- In case of malfunction, contact the service department.
- Before any maintenance, disconnect the machine from the electricity supply.
- Store in a dry, well-ventilated place and at room temperature.
- If you are not going to use the machine for a long time, unplug it from the power supply.

TRANSPORT

Before moving, make sure the machine is disconnected from the electricity supply.
Grasp the machine by the rear beam (47) and move it on the transport wheels (17).

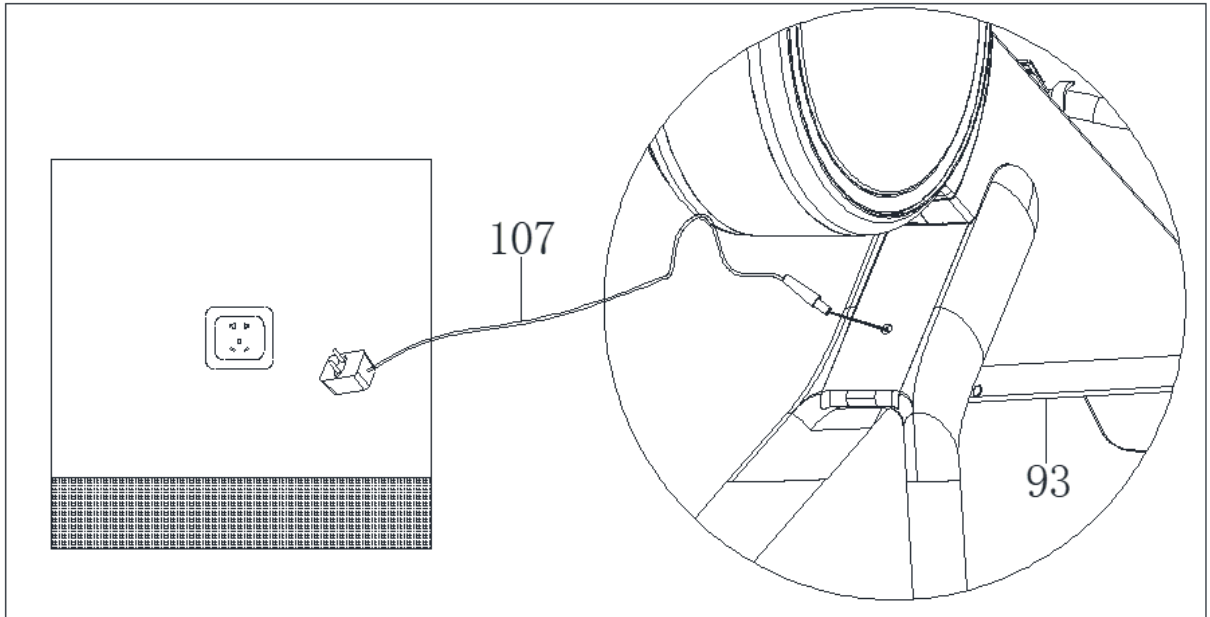
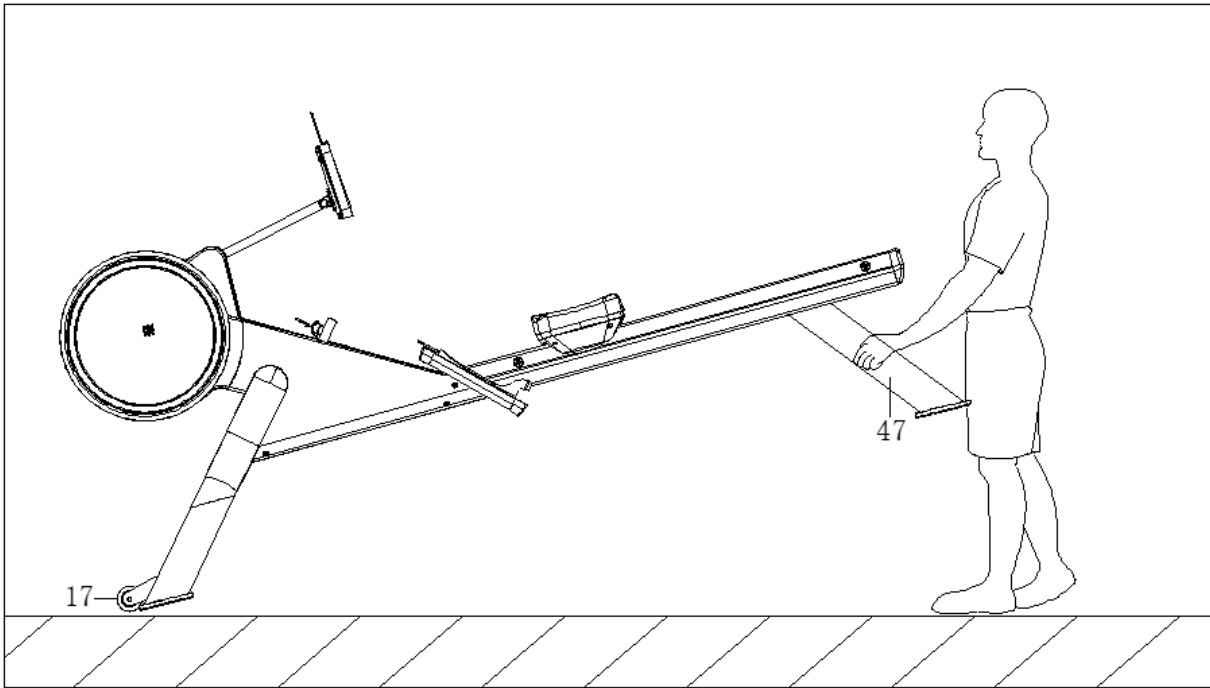

CONSOLE

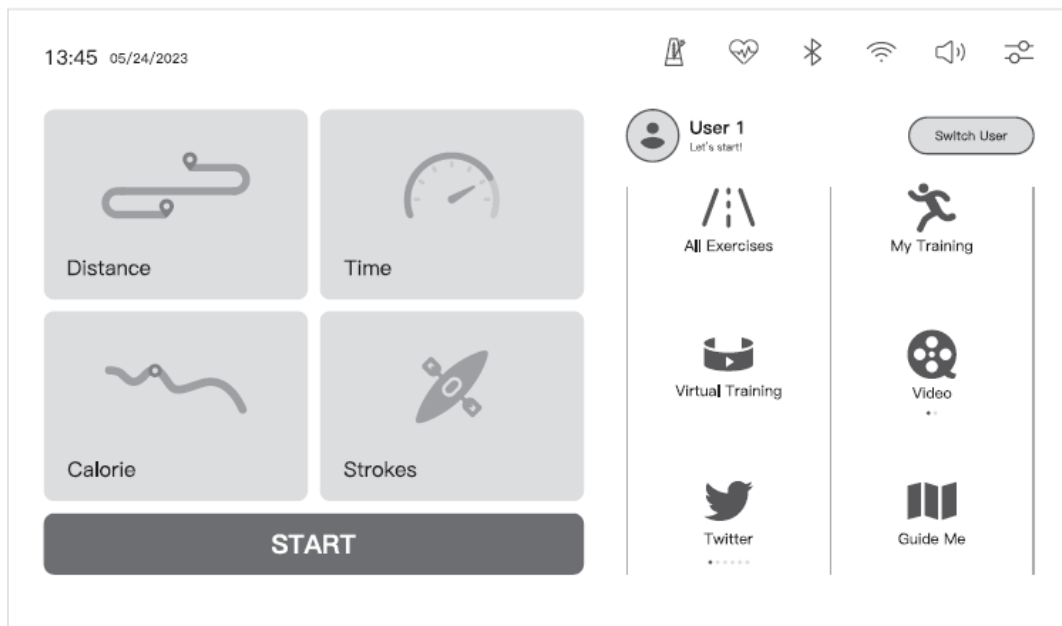









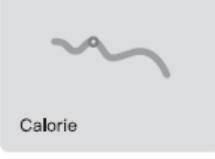
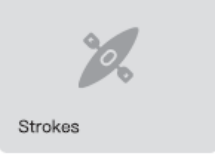

Status icons

Icon	Description
13:45 05/24/2023	Time and date
	Number of pulls You can set a target number of pull-ups and a sound notification by pressing
	Heart rate monitoring
	Bluetooth connection
	Wi-Fi connection intensity
	Wifi is not connected
	Adjust the volume
	Settings In the settings, you can set the Wifi connection, display brightness, language, measurement unit, time and others

Users

Icon	Description
User 1 Let's start!	After setting the data, your name will be displayed here
	Easy user change

Function description

 Distance	Countdown of the set distance
 Time	Countdown of the set time
 Calorie	Countdown of set calories burned
 Strokes	Countdown of set pulls
	Quick start
 All Exercises	HRC, constant power and preset programs
 My Training	Custom set programs
 Virtual Training	4 virtual programs
 Video	Local videos and music
 Twitter	Applications such as Twitter, Netflix, etc.
 Guide Me	Console instructions and commands

Programs

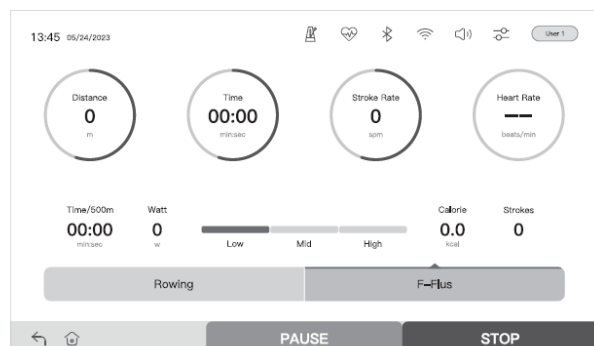
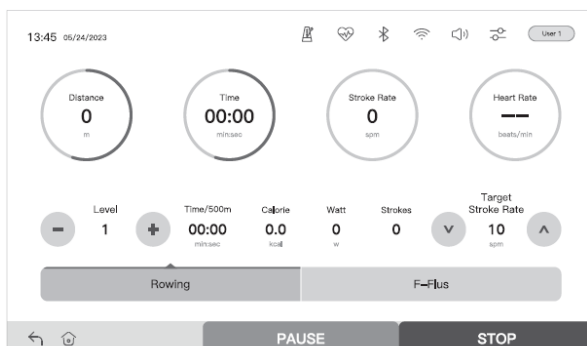

Rowing – regular program

F-Plus – strengthening program

When selecting: quick start, distance, time, calories and pull-ups you can choose from normal or strength mode

HRC program

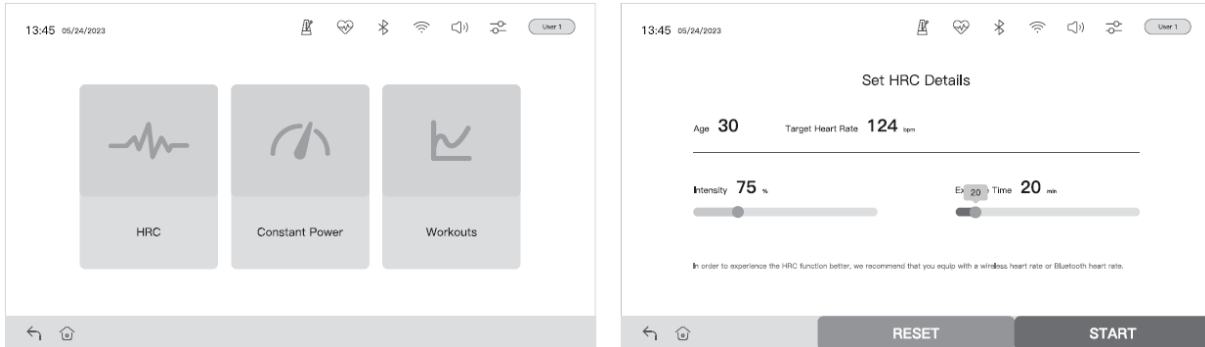

Heart rate program

Before using the HRC program, you should set up accurate user data in "My Training".

For better measurements, we recommend using a Bluetooth chest strap.

Preset programs (Workouts)

You can choose 3 levels of difficulty in the preset programs:

- Beginners
- Normal (Medium)
- Performance (high)
- Level (load)
- TSR (Target Strokes Per Minute)

		1	2	3	4	5	6	7	8	9	10	11	12	13	14	15	16	17	18	19	20		
Beginners	A1	Level	1	1	1	1	1	1	1	1	1	1	1	1	1	1	1	1	1	1	1	1	
		TSR	20	20	20	20	20	20	20	20	20	20	20	20	20	20	20	20	20	20	20	20	20
	A2	Level	8	8	8	1	8	8	8	1	8	8	8	1	8	8	8	1	8	8	8	1	1
		TSR	25	25	25	20	25	25	25	20	25	25	25	20	25	25	25	20	25	25	25	20	20
	A3	Level	24	24	24	18	24	24	24	18	24	24	24	18	24	24	24	18	24	24	24	24	18
		TSR	20	20	20	20	20	20	20	20	20	20	20	20	20	20	20	20	20	20	20	20	20
	A4	Level	16	16	16	8	16	16	16	8	16	16	16	8	16	16	16	8	16	16	16	16	8
		TSR	25	25	25	20	25	25	25	20	25	25	25	20	25	25	25	20	25	25	25	20	20
Normal	B1	Level	1	1	1	1	1	1	1	1	1	1	1	1	1	1	1	1	1	1	1	1	
		TSR	25	25	25	25	25	25	25	25	25	25	25	25	25	25	25	25	25	25	25	25	25
	B2	Level	12	12	12	12	12	12	12	12	12	12	12	12	12	12	12	12	12	12	12	12	12
		TSR	30	30	30	25	30	30	30	25	30	30	30	25	30	30	30	25	30	30	30	25	25
	B3	Level	24	24	24	18	24	24	24	18	24	24	24	18	24	24	24	18	24	24	24	24	18
		TSR	25	25	25	20	25	25	25	20	25	25	25	20	25	25	25	20	25	25	25	20	20
	B4	Level	24	24	24	16	24	24	24	16	24	24	24	16	24	24	24	16	24	24	24	24	16
		TSR	25	25	25	20	25	25	25	20	25	25	25	20	25	25	25	20	25	25	25	20	20
Performance	C1	Level	1	1	1	1	1	1	1	1	1	1	1	1	1	1	1	1	1	1	1	1	
		TSR	25	25	25	25	25	25	25	25	25	25	25	25	25	25	25	25	25	25	25	25	25
	C2	Level	24	24	24	12	24	24	24	12	24	24	24	12	24	24	24	12	24	24	24	12	12
		TSR	35	35	35	30	35	35	35	30	35	35	35	30	35	35	35	30	35	35	35	30	30
	C3	Level	48	48	48	24	48	48	48	24	48	48	48	24	48	48	48	24	48	48	48	24	24
		TSR	30	30	30	25	30	30	30	25	30	30	30	25	30	30	30	25	30	30	30	25	25
	C4	Level	24	24	48	48	24	24	48	48	24	24	48	48	24	24	48	48	24	24	48	48	24
		TSR	35	25	30	30	35	25	30	30	35	25	30	30	35	25	30	30	35	25	30	30	30

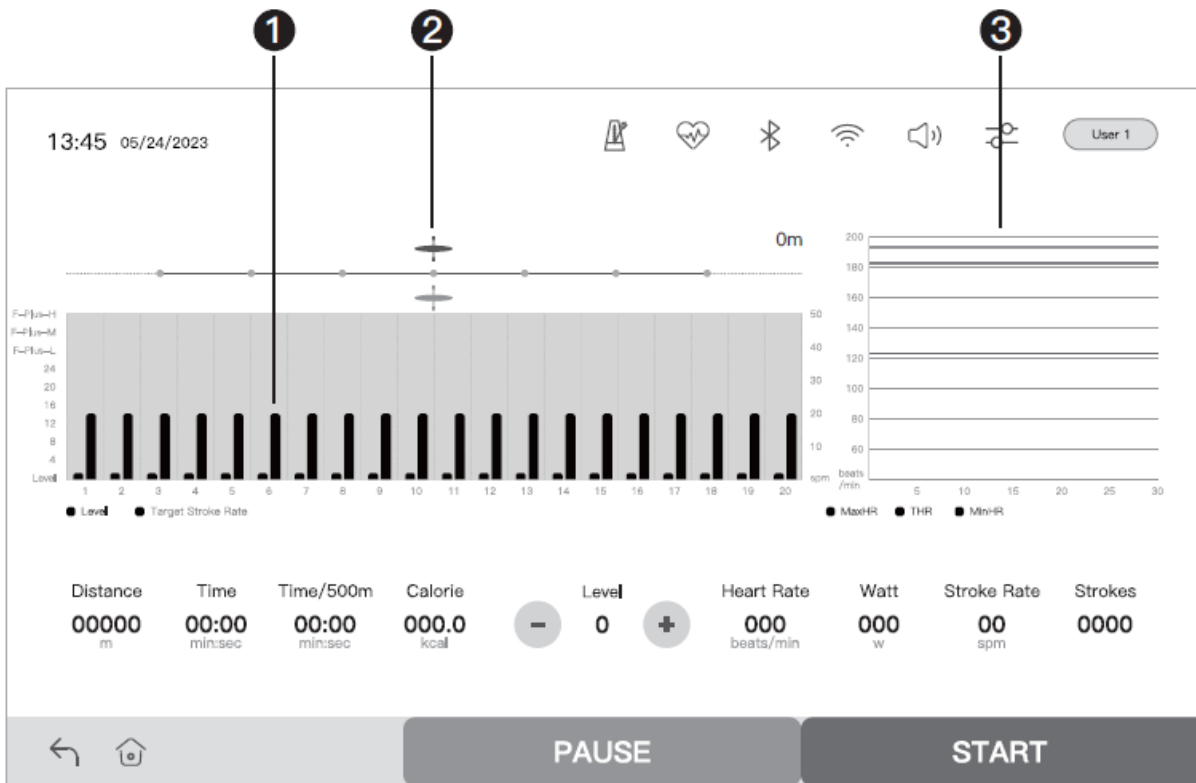

1. Current load and number of pulls per minute
2. The top pointer shows the system, the bottom pointer shows your progress.
3. Heart rate graph – target, maximum and current heart rate

WARNING! The heart rate frequency monitoring may not be completely accurate. Overexertion during training can lead to a serious injury or even death. If you start to feel faint, stop the exercise immediately.

WARNING:

To ensure the correct operation of the console, do not download or install other software.

Clean cache regularly.

The console may not connect to Wifi if the connection requires authentication.

Create an account on first launch.

WARM UP

Regular exercise begins with warming up and ends with rest exercises. The warm-up should prepare the body for the subsequent load. Rest exercises should then prevent muscle injuries and cramps. Perform warm-up and rest exercises according to the table below.



Toes on the toes

Lean forward. Keep your back and arms relaxed and lean forward to your toes. Hold in position for 15 seconds. Bend your knees slightly.



Upper thighs

Lean against the wall with one hand. Put your other hand behind you and grab your foot. Pull him to your buttocks. Hold for 30 seconds and repeat with the other leg.



Knees

Sit down and stretch your right leg. Place the sole of the left foot to the right inner thigh. Stretch your right arm to the tip of the outstretched leg. Hold for 15 seconds and release. Repeat also with the left foot.



Inner thighs

Sit on the floor with your toes together. The knees are pointing outwards. Pull your feet to your groin. Push your knees down. Hold for 30-40 seconds if possible.



Calf and Achilles tendons

Lean against the wall with one foot back and arms forward. Tighten your right foot and leave your left foot on the ground. Bend your left leg and push forward by pushing your hips towards the wall. Hold for 30 - 40 seconds. Keep your legs taut and repeat with the other leg.

The Exercise Phase

This is the stage where you put the effort in. After regular use, the muscles in your legs will become more flexible. Work at your own pace but be sure to maintain a steady tempo throughout. The rate of work should be enough to raise your heartbeat into the target zone shown on the graph below.

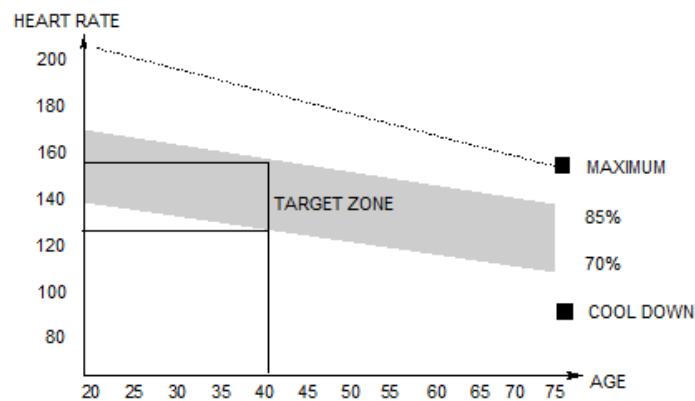

Cooling-Down Phase

This stage is to let your cardio-vascular system and muscles wind down. This is a repeat of the warm-up phase. First, reduce your tempo and continue at this slower pace for approximately 5 minutes before you get off your Exercise Bike. The stretching exercises should now be repeated, again remembering not to force or jerk your muscles into the stretch.

As you get fitter you may need to train longer and harder. It is advisable to train at least three times a week, and if possible, to space your workouts evenly throughout the week.

MUSCLE TONING

To tone muscle while exercising you will need to have the resistance set quite high. This will put more strain on our leg muscles and may mean you cannot train for as long as you would like. If you are also trying to improve your fitness you need to alter your training program. You should train as normal during the warm up and cool down phases, but towards the end of the exercise phase you should increase resistance making your legs work harder. You will have to reduce your speed to keep your heart rate in the target zone.

WEIGHT LOSS

The important factor here is the amount of effort you put in. The harder and longer you work the more calories you will burn. This is effectively the same as if you were training to improve your fitness, the difference being the goal.

Basic exercise

- 1) Sit on the saddle and fasten your feet to the pedals using the Velcro straps. Then take hold of the rowing bar.
- 2) Take up the starting position, leaning forward with your arms straight and knees bent as shown in (Pic 1).
- 3) Push yourself backwards, straightening your back and legs at the same time (Pic 2).
- 4) Continue this movement until you are leaning slightly backwards, during this stage you should bring your arms out of the side. (Pic 3). Then return to stage 2 and repeat. See attached.

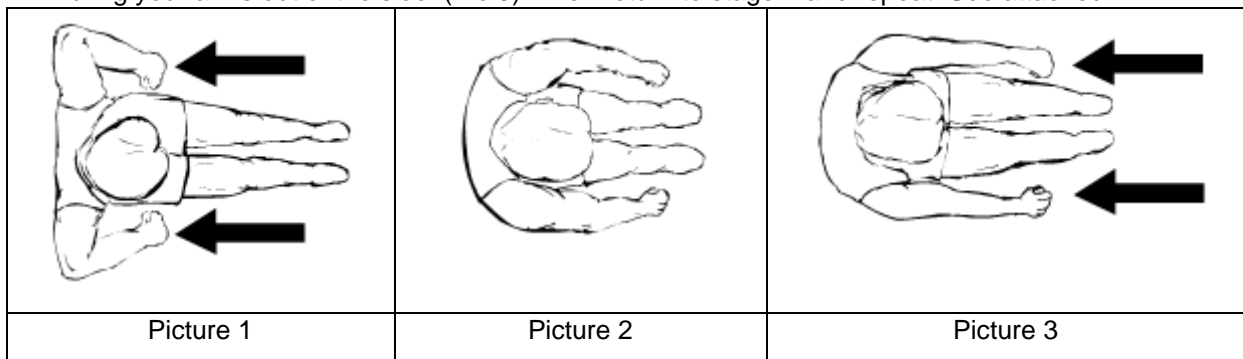

Training Time

Rowing is a strenuous form of exercise, because of this it is best to start with a short, easy exercise programmed and build up to longer and harder workouts. Start rowing for about 5 minutes and as you progress, increase the length of your work out to match your improving level of fitness. You should eventually be capable of rowing for 15-20 minutes, but do not try to achieve this too quickly.

Try to train on alternate days, 3 times a week. This gives your body time to recover between workouts.

Alternate Rowing Styles.

Arms Only Rowing

This exercise will tone muscles in your arms, shoulders, back and stomach. Sit as shown in Pic 4 with your legs straight, lean forward and grasp the handles. In a gradual and controlled manner lean back to just past the upright position continuing to pull the handles towards your chest. Return to the starting position and repeat. See attached.

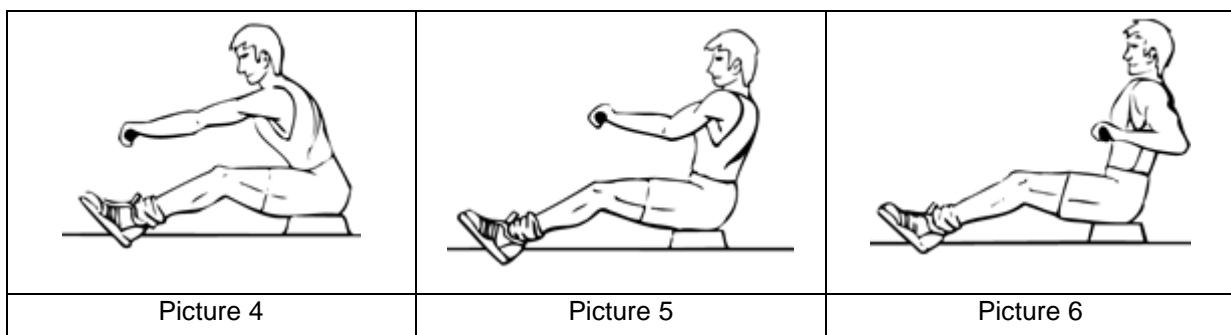

Legs Only Rowing

This exercise will help tone muscles in your legs and back. With your back straight and arms out stretched, bend your legs until you are grasping the rowing arm handles in the starting position, Pic 7. Use your legs to push your body back whilst keeping your arms and back straight

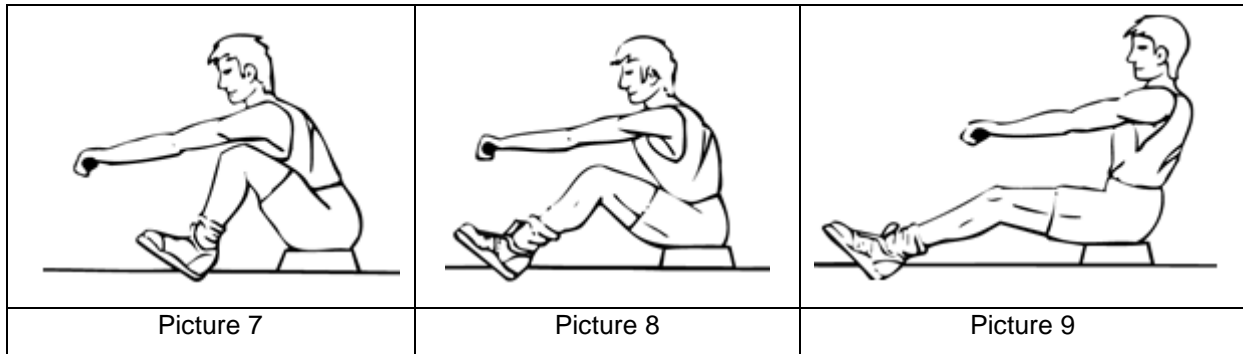

HOW TO EXERCISE

Phase of right rowing to strengthen specific muscles:

1. Stroke (Lower Muscle Exercise): Bend your knees and stretch your arms. Grasp the handle and keep your back straight (Pic 01).
2. Movement (center muscles): Reflect the legs and bend the arms (Pic 02).
3. End (upper body muscles): Take your back and legs tight. Hold your wrists straight and pull the handle (Pic 03).
4. Training the four-headed femoral muscle (Pic 04).
5. Muscle training on arms (Pic 05).
6. Practice of back and abdominal muscles (Pic 06)



Picture 01



Picture 02

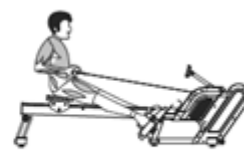

Picture 03



Picture 04



Picture 05



Picture 06

IMPORTANT NOTICE

- This rowing machine comes with standard safety regulations and is suitable for home use. We are not responsible for any injury caused by improper and forbidden use of the machine.
- Consult your doctor before starting training on the rowing machine. Your doctor should evaluate whether you are physically fit to use the machine and how much effort you are able to undergo. Incorrect exercise or switching of the body can harm your health.
- Carefully read the following tips and exercises. If you experience pain, nausea, breathing, or other health problems during exercise, immediately stop the exercise. If the pain persists, contact your doctor immediately.
- This rowing machine is not suitable as a professional or medical purpose. It can also not be used for healing purposes.

- The heart rate monitor is not a medical device. It provides only approximate information about your average heart rate, and any suggested pulse rate is not medically binding. Accumulated data may not always be accurate regarding uncontrollable human and environmental factors.

ENVIRONMENT PROTECTION

After the product lifespan expired or if the possible repairing is uneconomic, dispose it according to the local laws and environmentally friendly in the nearest scrapyards.

By proper disposal you will protect the environment and natural sources. Moreover, you can help protect human health. If you are not sure in correct disposing, ask local authorities to avoid law violation or sanctions.

Don't put the batteries among house waste but hand them in to the recycling place.

TERMS AND CONDITIONS OF WARRANTY, WARRANTY CLAIMS

General Conditions of Warranty and Definition of Terms

All Warranty Conditions stated here under determine Warranty Coverage and Warranty Claim Procedure. Conditions of Warranty and Warranty Claims are governed by Act No. 89/2012 Coll. Civil Code, and Act No. 634/1992 Coll., Consumer Protection, as amended, also in cases that are not specified by these Warranty rules.

The seller is SEVEN SPORT s.r.o. with its registered office in Strakonická street 1151/2c, Prague 150 00, Company Registration Number: 26847264, registered in the Trade Register at Regional Court in Prague, Section C, Insert No. 116888.

According to valid legal regulations it depends whether the Buyer is the End Customer or not.

"The Buyer who is the End Customer" or simply the "End Customer" is the legal entity that does not conclude and execute the Contract in order to run or promote his own trade or business activities.

"The Buyer who is not the End Customer" is a Businessman that buys Goods or uses services for the purpose of using the Goods or services for his own business activities. The Buyer conforms to the General Purchase Agreement and business conditions.

These Conditions of Warranty and Warranty Claims are an integral part of every Purchase Agreement made between the Seller and the Buyer. All Warranty Conditions are valid and binding, unless otherwise specified in the Purchase Agreement, in the Amendment to this Contract or in another written agreement.

Warranty Conditions

Warranty Period

The Seller provides the Buyer a 24 months Warranty for Goods Quality, unless otherwise specified in the Certificate of Warranty, Invoice, Bill of Delivery or other documents related to the Goods. The legal warranty period provided to the Consumer is not affected.

By the Warranty for Goods Quality, the Seller guarantees that the delivered Goods shall be, for a certain period of time, suitable for regular or contracted use, and that the Goods shall maintain its regular or contracted features.

Batteries

6-month battery warranty – we guarantee that battery's nominal capacity does not fall below 70% of its total capacity within 6 months of the product's sale.

The Warranty does not cover defects resulting from (if applicable):

- User's fault, i.e. product damage caused by unqualified repair work, improper assembly, insufficient insertion of seat post into frame, insufficient tightening of pedals and cranks
- Improper maintenance
- Mechanical damages

- Regular use (e.g. wearing out of rubber and plastic parts, moving mechanisms, joints, wear of brake pads/blocks, chain, tires, cassette/multi wheel etc.)
- Unavoidable event, natural disaster
- Adjustments made by unqualified person
- Improper maintenance, improper placement, damages caused by low or high temperature, water, inappropriate pressure, shocks, intentional changes in design or construction etc.

Warranty Claim Procedure

The Buyer is obliged to check the Goods delivered by the Seller immediately after taking the responsibility for the Goods and its damages, i.e. immediately after its delivery. The Buyer must check the Goods so that he discovers all the defects that can be discovered by such check.

When making a Warranty Claim the Buyer is obliged, on request of the Seller, to prove the purchase and validity of the claim by the Invoice or Bill of Delivery that includes the product's serial number, or eventually by the documents without the serial number. If the Buyer does not prove the validity of the Warranty Claim by these documents, the Seller has the right to reject the Warranty Claim.

If the Buyer gives notice of a defect that is not covered by the Warranty (e.g. in the case that the Warranty Conditions were not fulfilled or in the case of reporting the defect by mistake etc.), the Seller is eligible to require a compensation for all the costs arising from the repair. The cost shall be calculated according to the valid price list of services and transport costs.

If the Seller finds out (by testing) that the product is not damaged, the Warranty Claim is not accepted. The Seller reserves the right to claim a compensation for costs arising from the false Warranty Claim.

In case the Buyer makes a claim about the Goods that is legally covered by the Warranty provided by the Seller, the Seller shall fix the reported defects by means of repair or by the exchange of the damaged part or product for a new one. Based on the agreement of the Buyer, the Seller has the right to exchange the defected Goods for a fully compatible Goods of the same or better technical characteristics. The Seller is entitled to choose the form of the Warranty Claim Procedures described in this paragraph.

The Seller shall settle the Warranty Claim within 30 days after the delivery of the defective Goods, unless a longer period has been agreed upon. The day when the repaired or exchanged Goods is handed over to the Buyer is considered to be the day of the Warranty Claim settlement. When the Seller is not able to settle the Warranty Claim within the agreed period due to the specific nature of the Goods defect, he and the Buyer shall make an agreement about an alternative solution. In case such agreement is not made, the Seller is obliged to provide the Buyer with a financial compensation in the form of a refund.

CZ **SEVEN SPORT s.r.o.**

Registered Office: Strakonická 1151/2c, Praha 5, 150 00,
ČR

Headquarters: Dělnická 957, Vítkov, 749 01

Warranty & Service: Čermenská 486, Vítkov 749 01

CRN: 26847264

VAT ID: CZ26847264

Phone: +420 556 300 970

E-mail: eshop@insportline.cz
reklamace@insportline.cz
servis@insportline.cz

Web: www.inSPORTline.cz

SK **inSPORTline s.r.o.**

Headquarters, warranty & service center: Električná 6471,
Trenčín 911 01, SK

CRN: 36311723

VAT ID: SK2020177082

Phone: +421(0)326 526 701

E-mail: objednavky@insportline.sk

About shipping



reklamacie@insportline.sk
servis@insportline.sk
www.inSPORTline.sk

Web: